

定位珠 Z5140 INTERNAL LATCH LOCK (简体)

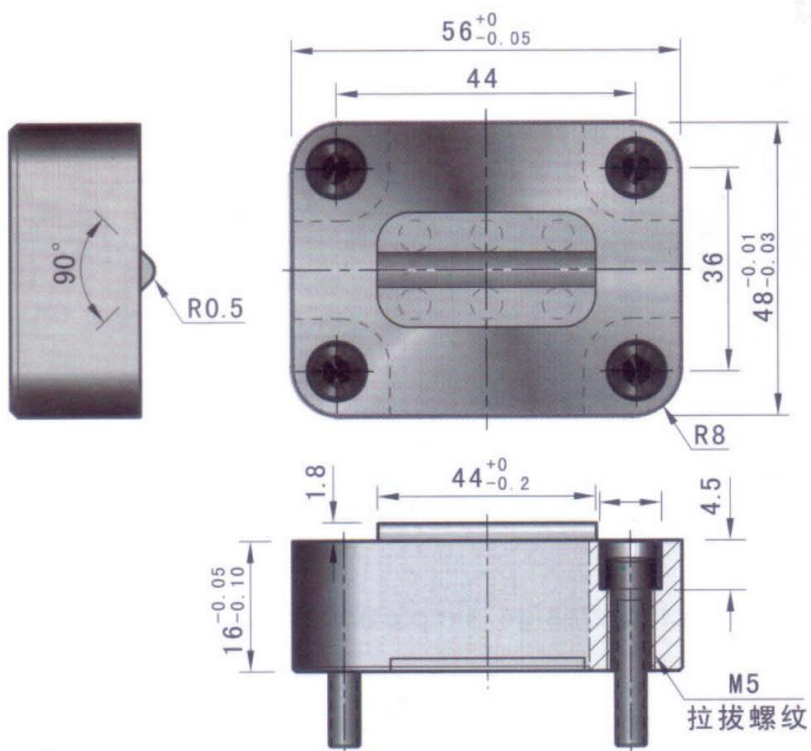

安裝使用說明:

依開框尺寸示意圖加工安裝槽；

產品後續取出時，用拉拔器一端連接產品上的拉拔螺紋拔出即可。

Code	安裝螺絲	荷重(Kgf)
Z5140-2	M4-25	25

開框尺寸示意圖:

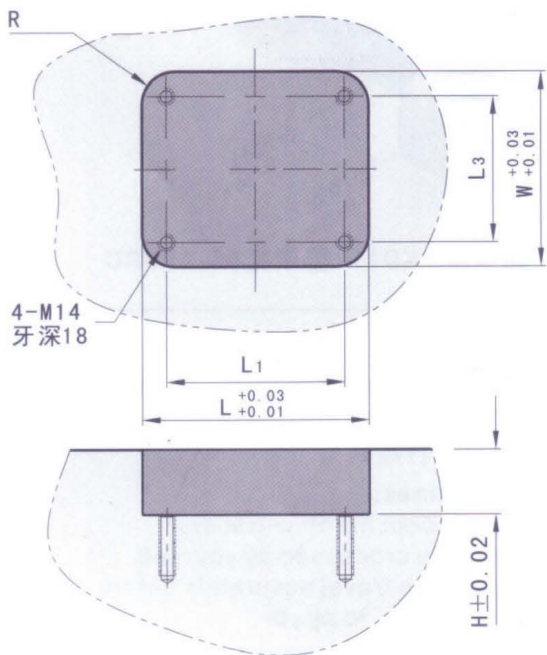

安裝示意圖:

