

ROA:ROA+TC TYPE

圓型中型油壓缸TC尺寸图 14Mpa RO Series TC Dimensional Features

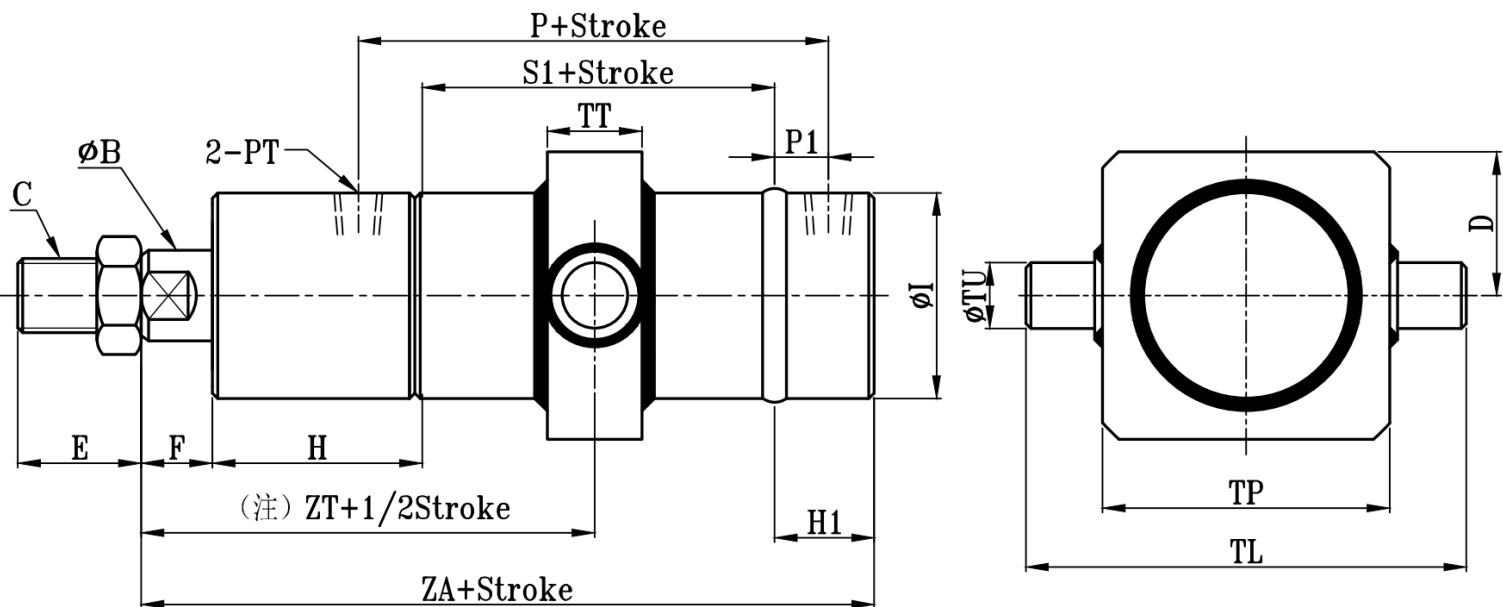

ROD:ROD+TC TYPE

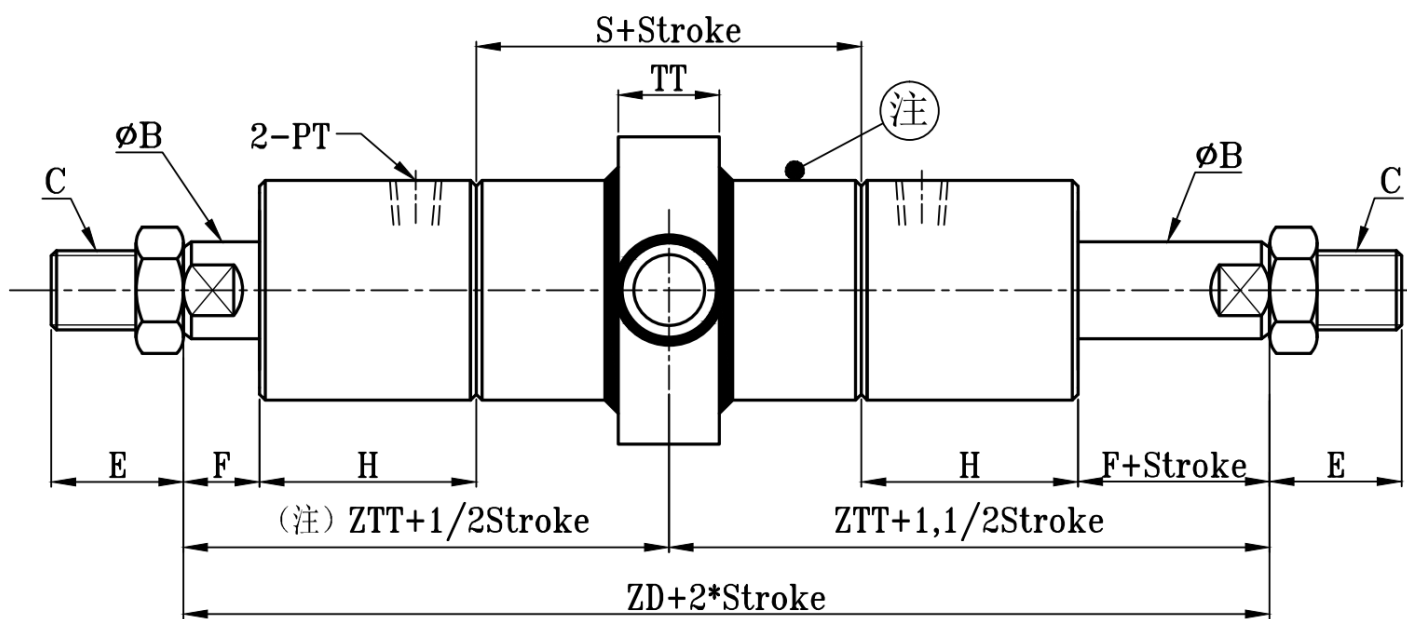

注:感应油缸时, 不论是单轴还是双轴缸, 缸筒长度的选择均为双轴缸的缸筒长度

缸径 BORE	ROB-ROD TYPE													TC (耳轴型) TYPE							
	ΦB	C	E	F	H1	H	ΦI	P	P1	PT	s1	S	ZA	ZD	ZT	ZTT	ΦTU	TL	TP	TT	D
$\Phi 32$	16	M14xP1.5	30	15	25	50	42	81	10.5	1/4	60	80	150	210	95	105	18	92	62	18	25
$\Phi 40$	20	M16xP1.5	30	15	25	50	50	84	12	3/8	60	80	150	210	95	105	22	115	77	22	32.5
$\Phi 50$	25	M22xP1.5	40	20	30	60	60	95	12	3/8	71	95	181	255	115.5	127.5	27	140	92	27	40
$\Phi 63$	35	M30xP1.5	40	20	30	60	73	95	12	3/8	71	95	181	255	115.5	127.5	32	160	102	32	45
$\Phi 80$	40	M30xP1.5	45	25	35	70	92	113	15	1/2	83	110	213	300	136.5	150	37	190	122	37	55
$\Phi 100$	50	M40xP2.0	50	25	35	70	114	123	15	1/2	93	120	223	310	141.5	155	44	233	155	44	65
$\Phi 125$	60	M50xP2.0	60	30	40	80	140	136	19	3/4	98	130	248	350	159	175	54	277	180	54	81
$\Phi 140$	70	M60xP2.0	70	30	40	80	160	136	19	3/4	98	130	248	350	159	175	54	300	200	54	95
$\Phi 150$	80	M70xP2.0	80	30	45	90	168	151	19	3/4	113	150	278	390	176.5	195	64	330	212	64	97.5
$\Phi 160$	80	M70xP2.0	80	30	45	90	178	151	19	3/4	113	150	278	390	176.5	195	64	340	222	64	102.5
$\Phi 180$	100	M90xP2.0	100	35	50	100	200	177	23.5	1	130	170	315	440	200	220	70	400	255	70	117.5
$\Phi 200$	100	M90xP2.0	100	35	50	100	228	177	23.5	1	130	170	315	440	200	220	70	425	277	70	130.5
$\Phi 220$	125	M100xP3.0	110	35	55	110	250	203	28	1 1/4	147	190	347	480	218.5	240	80	480	302	80	142.5
$\Phi 250$	125	M100xP3.0	110	35	55	110	276	203	28	1 1/4	147	190	347	480	218.5	240	80	510	332	80	157.5

注:ZT、ZTT尺寸可按要求做