

特點: 安裝加工簡單, 機械互鎖設計, 安全可靠, 可根據模具荷重選擇對應產品, 在模闔上至少要2套并對稱使用。 使用溫度範圍120°C

Characteristics: Installation and processing are simple. Design of mechanical interlock is safe and reliable. Connecting body and square positioning make product more accurate. People can select corresponding product according to die load. There shall be at least 2 sets on template for symmetrical use. Operating temperature range is 120°C.

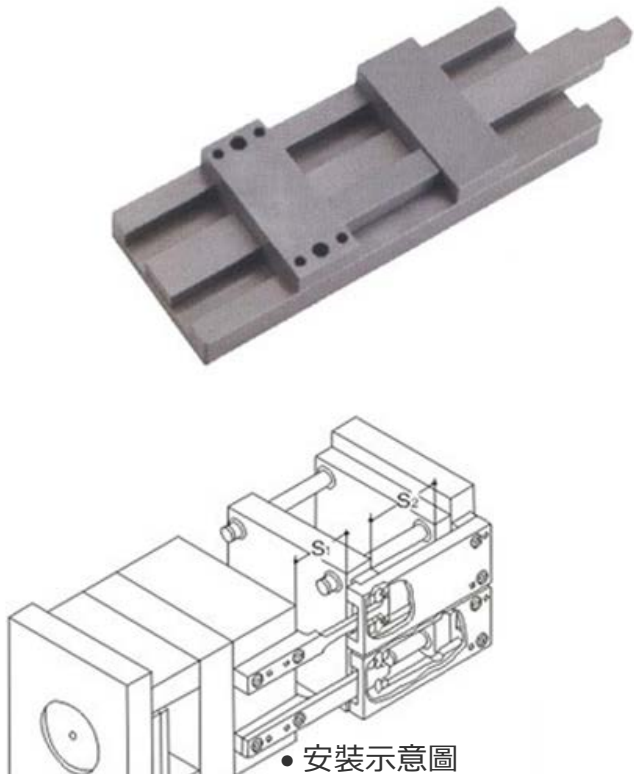

● 安裝示意圖

Installation diagram

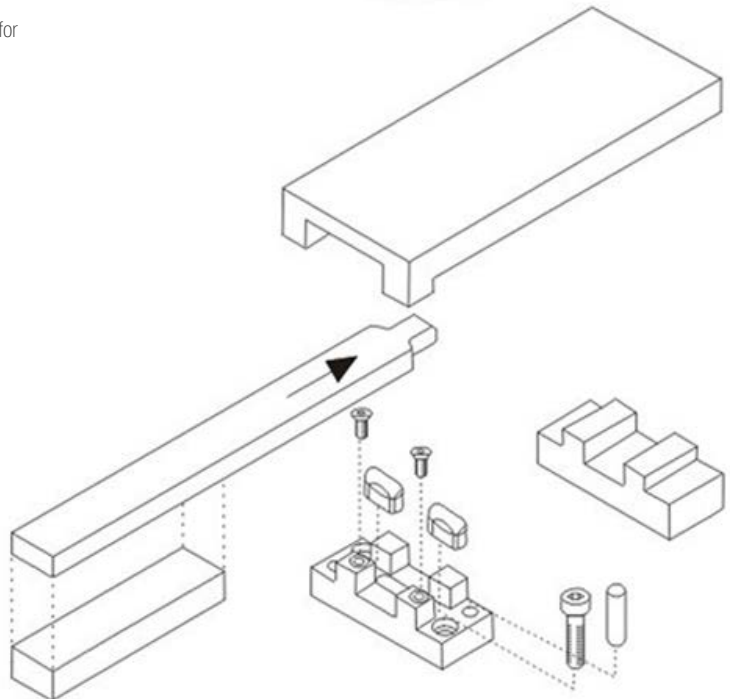

● 產品分解圖

Product breakdown drawing

※ 注意事項: 在模具加工中, 必須計算相同的行程對稱安裝, 否則會導致單套鎖模扣受力不平衡, 導致組件斷裂。

※ Precautions: It is required to calculate the same stroke for symmetrical installation during die processing. Otherwise, it will cause unbalance force of single set of modelocking buckle and breakage of component.

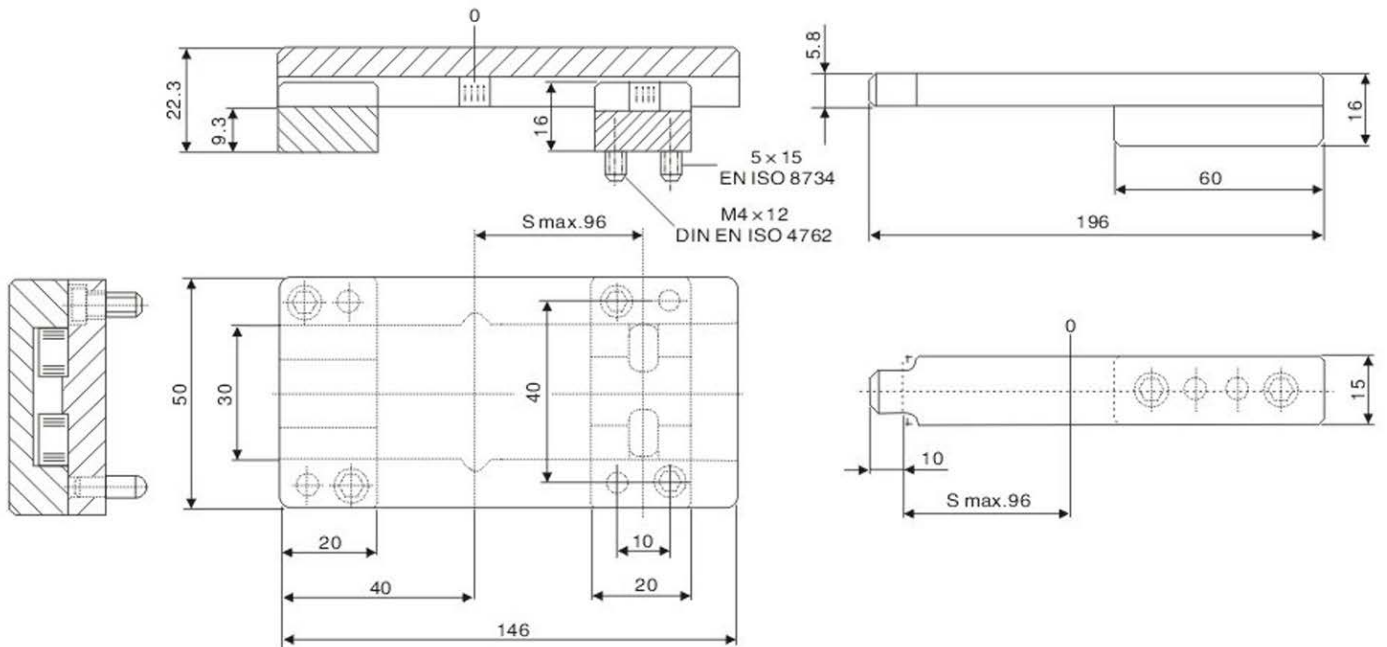

Order: Type No. x Pcs
Z6-1 X 10

2D下載

3D下載

返回索引